

ANALOG TIMER : TATP-180S

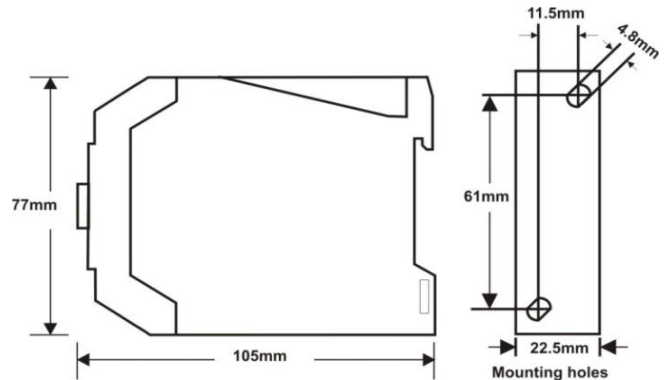

Dimensions

All dimensions in mm

True Power OFF Delay

FEATURES	<ul style="list-style-type: none"> True Power OFF Delay Low Cost High Reliability Compact DIN Rail / Base Mounting 	TIME RANGES	
		0 - 60 Sec 0 - 180 Sec (Refer NOTE below)	
OPERATING MODES	True Power OFF Delay		
INDICATIONS	LED Status Indicator : Power ON		
SUPPLY VOLTAGE	SUPPLY VOLTAGE	110 to 240V AC / DC , 47 – 63Hz (Refer ordering information below)	
	POWER CONSUMPTION	2.5VA Max	
	INRUSH CURRENT	Maximum. 5A, at 240V AC for 20ms	
ISOLATION	Supply Terminals – Contacts : 1.5KV, 1min Contact Set1 – Contact Set2 : 1.5KV, 1min		
OUTPUT SPECIFICATION	OUTPUT CONTACT	DPDT (2 C/O)	
	CONTACT RATING	2.5A@230V AC	
ACCURACY	Setting : ±5% of Full Scale, Repeat : ± 0.5% or 50msec		
RESET	On resumption of power, Reset time < 100msec		
ENDURANCE	POTENTIOMETER	MECHANICAL : 1000 Cycles	
	RELAY	MECHANICAL : 10,000,000 ops. Minimum (1800 ops./hr.) ELECTRICAL : 100,000 ops. Minimum (1200 ops./hr.)	
AMBIENT CONDITIONS	OPERATING AMBIENT	0-55°C, 85% RH	
	STORAGE AMBIENT	-20°C to 85°C	
	HUMIDITY	95% RH non condensing	
GENERAL SPECIFICATIONS	TERMINATIONS	Screw type, for 2.5mm sq. wire	
	MOUNTING	DIN rail / Base Mount	
	WEIGHT	120 gms	
	PROTECTION LEVEL	IP40 for housing, IP20 for terminals, Finger Safe Terminals	
ORDERING INFORMATION\	TATP - 180S - Z		
	DESIGN NO.	TIME RANGES	SUPPLY VOLTAGE
	TATP	60S : 60 Sec 180S : 180 Sec	Z : 110 to 240V AC / DC , 47 - 63Hz

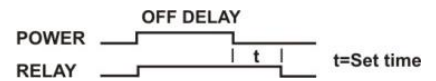

Timing Diagram

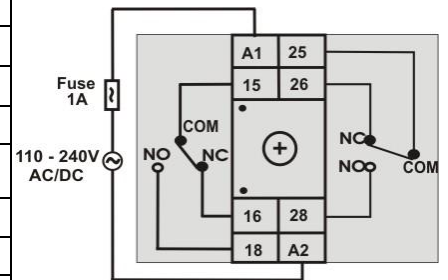

Terminal Connections

NOTE : If the time setting is altered , it will be effective from next cycle.